

**TECHNISCHE
DATEN**



**KETTENBAGGER 520X
X-PECT MORE**

JCB

ERWARTEN SIE MEHR VOM 520X

Auf der Grundlage unserer langjährigen Erfahrung in der Konstruktion von Baggern haben wir gemeinsam mit Eigentümern und Fahrern die beste Maschine der 50-Tonnen-Klasse auf dem Markt entwickelt. Jedes Detail unserer neuen Maschine ist darauf ausgelegt, herausragende Leistung, Effizienz, Sicherheit, Komfort und Zuverlässigkeit zu bieten, sodass Sie sich darauf verlassen können, Ihre Aufgaben stets erfolgreich zu bewältigen.



EXTRA EFFIZIENZ

Das japanische Hydrauliksystem der neuesten Generation wurde auf maximale Effizienz ausgelegt und verfügt serienmäßig über eine regenerative Hydraulik sowie ein hydraulisch angetriebenes Kühlsystem mit Umkehrlüfter.



EXTRA STÄRKE

Der 520X wurde einem umfassenden Testprogramm unterzogen und verfügt über unser Heavy-Duty-Laufwerk sowie unser stabilstes Auslegerdesign. Diese gewährleisten auch unter extremen klimatischen Bedingungen und bei anspruchsvollen Einsätzen höchste Festigkeit und Zuverlässigkeit.



EXTRA LEISTUNG

Ein leistungsstarker Cummins X12-Motor, ein Doppelschwenkmotorsystem und Löffel mit großer Kapazität liefern herausragende Arbeitsspiele. Mit dem optionalen, variablen Laufwerk und dem abnehmbaren Kontergewicht lässt sich der 520X einfacher zu rauen Arbeitsumgebungen transportieren.



EXTRA KONTROLLE

Profitieren Sie von einem 10-Zoll-Touchscreen-Display mit erstklassigem Benutzeroberflächendesign und vollständig anpassbaren Joystick-Bedienelementen. Sie haben die Möglichkeit, 15 verschiedene hydraulische Anbaugeräte zu speichern und Durchflussmengen sowie Drücke individuell anzupassen, um die Leistung von Maschine und Anbaugerät zu optimieren.



EXTRA KOMFORT

Neben der größten Kabine ihrer Klasse und dem geringsten Kabineninnengeräuschpegel sorgen ein serienmäßiger beheizbarer und belüfteter Sitz sowie vollständig verstellbare Bedienelemente dafür, dass sich die Fahrer während der gesamten Schicht wohlfühlen.

JCBUX

Wir haben unsere geräumige JCB CommandPlus-Kabine, die in ihrer Klasse führend ist, aktualisiert und mit JCB UX ausgestattet, um Ihnen noch mehr Komfort und Kontrolle zu bieten. Ein neues 10-Zoll-Vollfarb-Touchscreen-Display, überarbeitete Bedienelemente und ein schlüsselloser Start machen die Bedienung einfacher und schneller als je zuvor. Die überarbeitete Menüoberfläche bietet Ihnen zudem die Möglichkeit, Funktionen über verschiedene Eingabemöglichkeiten zu steuern und so produktiver und effizienter zu arbeiten.



STATISCHE ABMESSUNGEN

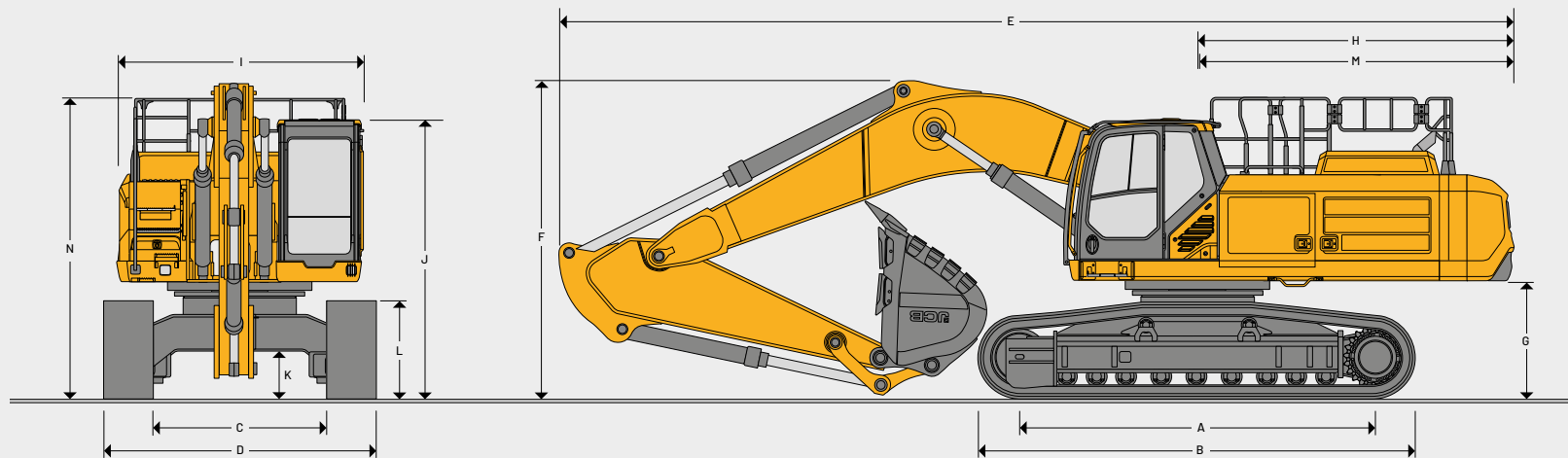

Modell		520X FG – Feste Spurweite		520X FV – Variable Spurweite	
A	Kettenaufstandslänge	mm	4.370	4.370	
B	Laufwerksgesamtlänge	mm	5.368	5.368	
C	Spurweite - Ausfahren	mm	2.740	2.890	
	Spurweite - Eingefahren	mm	N. z.	2.390	
D	Laufwerksbreite (600-mm-Bodenplatte)	mm	3.340	2.990	
D	Laufwerksbreite (700-mm-Bodenplatte)	mm	3.440	3.090	
D	Laufwerksbreite (800-mm-Bodenplatte)	mm	3.540	3.190	
D	Laufwerksbreite (900-mm-Bodenplatte)	mm	3.640	3.290	
G	Bodenfreiheit Kontergewicht	mm	1.381	1.381	
H	Hecklänge	mm	3.881	3.881	
I	Oberwagenbreite	mm	3.273	3.273	
I	Oberwagenbreite mit seitlicher Plattform	mm	3.520	3.520	
J	Höhe über Kabine	mm	3.419	3.419	
K	Bodenfreiheit	mm	566	724	
L	Kettenhöhe	mm	1.153	1.181	
M	Heckschwenkradius	mm	3.919	3.919	
N	Oberwagen-Gesamthöhe (Höhe über Haltegriff)	mm	3.670	3.670	
Auslegeroption			Mono 6,5 m		
Löffelstiellänge		2,55 m – ME – Massenaushub	3,0 m – ME – Massenaushub		
E	Transportlänge	mm	11.796	11.726	
F	Transporthöhe	mm	4.106	4.037	
Auslegeroption			6,9 m		
Löffelstielängen			3,0 m	3,3 m	3,9 m
E	Transportlänge	mm	12.177	12.109	12.103
F	Transporthöhe	mm	3.919	3.830	3.871

Löffel für statische Abmessungen 3,4-cum-Löffel - hd 404/V3551

KETTENBAGGER 520X

MOTOR	
Modell	Cummins X12 Tier 4 Final/Stufe V
Typ	4-Takt-/6-Zylinder-Reihenmotor, Direkteinspritzung, Diesel-Turbolader
Nennleistung (netto) – Motor	289 kW (387 PS) bei 1.400 U/min
Nennleistung (netto) – Maschine	289 kW (387 PS) bei 1.400 U/min
Nennleistung (brutto) – Motor (ISO 14396)	298 kW (400 PS) bei 1.800 U/min
Nennleistung (brutto) – Motor (SAE J1995)	298 kW (400 PS) bei 1.800 U/min
Hubraum	11,8 Liter
Luftfilterung	Trockenelement mit Warnanzeige in der Kabine
Anlasser	24 Volt
Batterien	2 x 12 Volt, 1.000 CCA
Lichtmaschine	24 Volt – 120 Ampere
Maximale Drehzahl	1.969 Nm bei 1.400 U/min

SCHWENKSYSTEM	
Schwenkmotor	Axialkolbentyp
Schwenkbremse	Hydraulische Bremse sowie automatisch wirkende Federspeicher-Scheibenfeststellbremse
Schwenkmoment	173 kNm
Schwenkgeschwindigkeit	9,2 rpm
Drehkranz	Großer Durchmesser, innenverzahnt, in vollständig abgedichtetem Fettbad drehend
Schwenksperr	Schaltbare Bremse in der Kabine

LAUFWERK						
Laufwerkoptionen	FG – Feste Spurweite VG – Variable Spurweite					
Konstruktion	Vollständig geschweißter „X“-Rahmen, mittiger Unterbodenschutz und geneigte Längsträger mit Schmutzlöchern unter den oberen Rollen					
Schleppvorrichtung	Vorn und hinten					
Obere und untere Laufrollen	Wärmebehandelt, versiegelt und geschmiert					
Ketteneinstellung	Fetzylindertyp					
Laufkettenrad	Versiegelt und geschmiert, mit gedämpftem Federrückstoß					
Kettentyp	Versiegelt und geschmiert					
Bodenplattenoptionen	600-mm-Zweifachsteg HD	700-mm-Zweifachsteg HD	600-mm-Dreifachsteg HD	700-mm-Dreifachsteg HD	800-mm-Dreifachsteg HD	900-mm-Dreifachsteg HD
	FG / VG	FG / VG	FG / VG	FG / VG	FG / VG	FG / VG
			600-mm-Dreifachsteg	700-mm-Dreifachsteg	800-mm-Dreifachsteg	900-mm-Dreifachsteg
			FG / VG	FG / VG	FG / VG	FG / VG
	Feste Spurweite			Variable Spurweite		
Anzahl obere Rollen (pro Seite)	2			3		
Anzahl untere Rollen (pro Seite)	9			9		
Anzahl Kettenführungen (pro Seite)	3			3		
Anzahl Bodenplatten (pro Seite)	49			49		

FAHRANTRIEB		
Typ	Voll hydrostatisches Zweiganggetriebe mit Automatikschaltung	
Fahrmotoren	Verstellbarer Axialkolbenmotor mit Schrägachse, geschützt im Laufwerksrahmen	
Endantrieb	Planetenuntersetzung, angeschraubte Kettenräder	
Betriebsbremse	Hydraulisch betätigte Bremse mit Ausgleichventil	
Feststellbremse	Automatisch wirkende, hydraulisch lösende Federspeicher-Scheibenbremse	
Steigfähigkeit	70 % (35°) kontinuierlich	
Fahrgeschwindigkeit	km/h	Hoch – 5,1 Niedrig – 3,1
Schubkraft	kN	378,7

HYDRAULIKSYSTEM		
Pumpen		
Hauptpumpen	2 Axialkolben-Verstellpumpen	
Maximaler Fluss	l/min	2 x 404
Servopumpe	Zahnradpumpe	
Maximaler Fluss	l/min	27
Steuerventil		
Kombiniertes 4- und 5-Kreis-Steuerventil serienmäßig mit einem Zusatzkreis-Wartungsschieber		
Einstellungen des Druckbegrenzungsventils		
Ausleger/Hubgerüst/Löffel	bar	343
Mit Kraftverstärkung	bar	363
Schwenkkreis	bar	315
Fahrkreis	bar	324
Vorsteuerung	bar	40
Filtersystem		
Im Tank	105 µm, Ansaugsieb	
Hauptrücklaufleitung	10 µm, Glasfaserelement	
Vorsteuerleitung	10 µm, Glasfaserelement	
Rücklauf, hydraulischer Hammer	5 µm, verstärktes Mikrofaserelement	

Hydraulische Zylinder	Menge	Bohrung mm	Stangendurchmesser mm
Ausleger	2	170	115
Löffelstiel	1	190	130
Hubgerüst – ME	1	190	130
Schaufel	1	160	120
Löffel – ME	1	170	120

FÜLLMengen		
Kraftstofftank	Liter	657
Motor Kühlmittel	Liter	46
Motoröl	Liter	33
Schwenkuntersetzungsgetriebe	Liter	2x 6
Kettenuntersetzungsgetriebe (jede Seite)	Liter	2x 9
Hydrauliksystem	Liter	450
Hydrauliktank	Liter	220
DEF-Flüssigkeit	Liter	25

GEWICHTE UND BODENDRÜCKE

Schnellwechsler + 2,8-m³-HD-Löffel 2.886 kg, Bediener 75 kg, voller Kraftstofftank und 3,23-m-HD-Hubgerüst

		600 mm HD Dreifach- steg	700 mm HD Dreifach- steg	800 mm HD Dreifach- steg	900 mm HD Dreifach- steg	600 mm HD Zweifach- steg	700 mm HD Zweifach- steg
520X FG, volle Kettenführung, ME-Ausleger							
Maschinengewicht	kg	55.243	55.813	56.390	56.961	55.113	55.663
Bodendruck	kg/cm ²	1,05	0,91	0,81	0,72	1,05	0,91

520X VG, volle Kettenführung, ME-Ausleger

Maschinengewicht	kg	56.729	57.299	57.875	58.446	56.599	57.149
Bodendruck	kg/cm ²	1,08	0,94	0,83	0,74	1,08	0,93

QH+ 2,8-m³-HD-Löffel 2.886 kg, Bediener 75 kg, voller Kraftstofftank und 3,23-m-HD-Hubgerüst

		600 mm HD Dreifach- steg	700 mm HD Dreifach- steg	800 mm HD Dreifach- steg	900 mm HD Dreifach- steg	600 mm HD Zweifach- steg	700 mm HD Zweifach- steg
520X FG, volle Kettenführung, ME-Ausleger							
Maschinengewicht	kg	55.458	56.028	56.604	57.176	55.328	55.878
Bodendruck	kg/cm ²	1,06	0,92	0,81	0,73	1,06	0,91

520X VG, volle Kettenführung, ME-Ausleger

Maschinengewicht	kg	56.943	57.514	58.090	58.661	56.813	57.364
Bodendruck	kg/cm ²	1,09	0,94	0,83	0,75	1,08	0,94

QH+ 2,8-m³-HD-Löffel 2.886 kg, Bediener 75 kg, voller Kraftstofftank und 3,23-m-LITE-Hubgerüst

		600 mm HD Dreifach- steg	700 mm HD Dreifach- steg	800 mm HD Dreifach- steg	900 mm HD Dreifach- steg	600 mm HD Zweifach- steg	700 mm HD Zweifach- steg
520X FG, volle Kettenführung, Standardausleger							
Maschinengewicht	kg	55.112	55.682	56.258	56.829	54.982	55.532
Bodendruck	kg/cm ²	1,05	0,91	0,81	0,72	1,05	0,91

520X VG, volle Kettenführung, Standardausleger

Maschinengewicht	kg	56.597	57.168	57.744	58.315	56.467	57.018
Bodendruck	kg/cm ²	1,08	0,94	0,83	0,74	1,08	0,93

QH+ 2,8-m³-HD-Löffel 2.886 kg, Bediener 75 kg, voller Kraftstofftank und 3,23-m-Hubgerüst

		600 mm HD Dreifach- steg	700 mm HD Dreifach- steg	800 mm HD Dreifach- steg	900 mm HD Dreifach- steg	600 mm HD Zweifach- steg	700 mm HD Zweifach- steg
520X FG, volle Kettenführung, Standardausleger							
Maschinengewicht	kg	55.248	55.819	56.395	56.966	55.118	55.669
Bodendruck	kg/cm ²	1,05	0,91	0,81	0,72	1,05	0,91

520X VG, volle Kettenführung, Standardausleger

Maschinengewicht	kg	56.734	57.304	57.880	58.451	56.604	57.154
Bodendruck	kg/cm ²	1,08	0,94	0,83	0,74	1,08	0,93

QH+ 2,8-m³-HD-Löffel 2.886 kg, Bediener 75 kg, voller Kraftstofftank und 3,9-m-Hubgerüst

		600 mm HD Dreifach- steg	700 mm HD Dreifach- steg	800 mm HD Dreifach- steg	900 mm HD Dreifach- steg	600 mm HD Zweifach- steg	700 mm HD Zweifach- steg
520X FG, volle Kettenführung, Standardausleger							
Maschinengewicht	kg	55.509	56.079	56.656	57.227	55.379	55.929
Bodendruck	kg/cm ²	1,06	0,92	0,81	0,73	1,06	0,91

520X VG, volle Kettenführung, Standardausleger

Maschinengewicht	kg	56.995	57.565	58.141	58.712	56.865	57.415
Bodendruck	kg/cm ²	1,09	0,94	0,83	0,75	1,09	0,94

Löffel für Gewichte - 2,8 m³-HD-LÖFFEL (GESETZLICH GEREGLT) - (980/B5001 - GA - 50T-HD-LÖFFEL 1.900 mm)

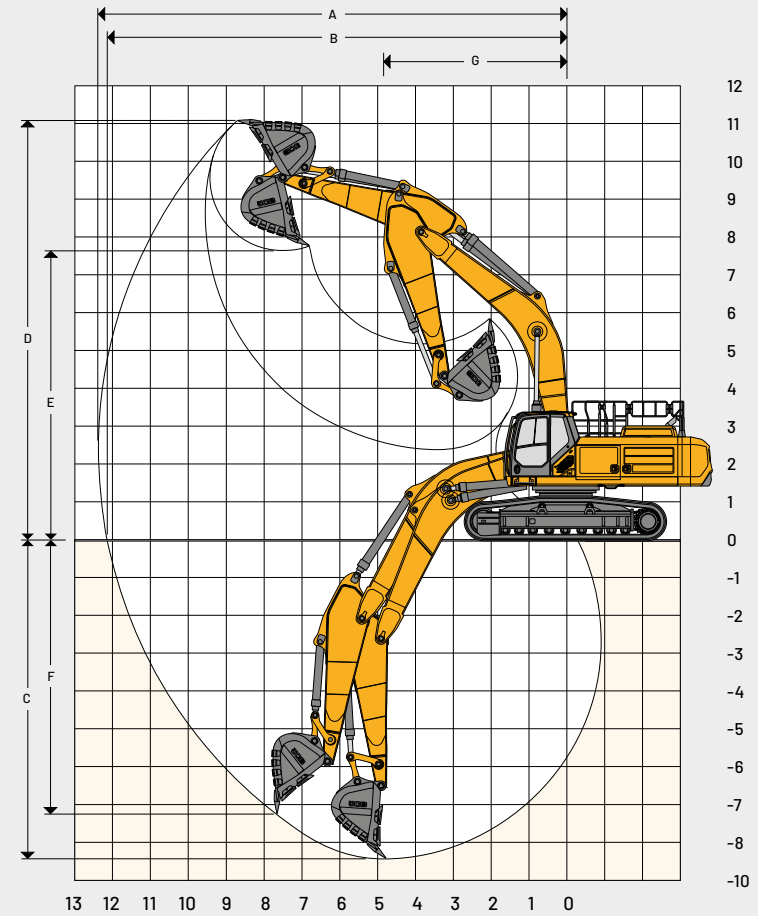
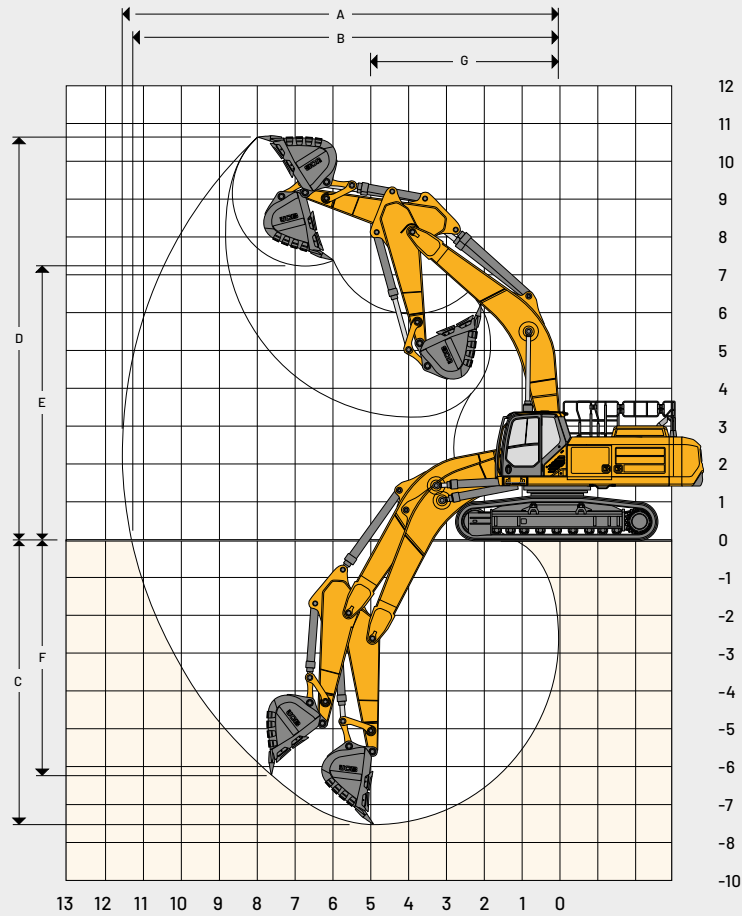



















ARBEITSBEREICH

Auslegerlänge und -art		Monoausleger 6,9 m Mass Excavation	
Löffel		3,1 Cu.M - HD 404/B6067 (1.938 mm)	
Stiellänge		2,55 m	3,0 m HD
A	Max. Grabreichweite (mm)	mm 10.923	11.353
B	Max. Grabreichweite (am Boden)	mm 10.691	11.093
C	Max. Grabtiefe	mm 6.801	7.251
D	Max. Schürfhöhe	mm 10.926	11.169
E	Max. Schütthöhe	mm 7.293	7.537
F	Max. vertikale Grabtiefe	mm 6.170	6.609
G	Mindestschwenkradius	mm 4.776	4.858
H	Min. Schütthöhe	mm 3.412	2.939
	Schaufelrotation	Grad 164	164
	Max. Ausbrechkraft Löffelstiel	kN 278,8	242
	Max. Reißkraft Schaufel	kN 318,3	318,3

ARBEITSBEREICH

Auslegerlänge und -art		Monoausleger 6,9 m		
Löffel		3,1 Cu.M - HD 404/B6067 (1.938 mm)		
Stiellänge		3,0 m Lite	3,3 m	3,9 m
A	Max. Grabreichweite (mm)	mm 11.498	10.962	12.359
B	Max. Grabreichweite (am Boden)	mm 11.248	11.575	12.121
C	Max. Grabtiefe	mm 7.540	7.840	8.440
D	Max. Schürfhöhe	mm 10.706	10.962	11.147
E	Max. Schütthöhe	mm 7.287	7.500	7.687
F	Max. vertikale Grabtiefe	mm 6.239	6.719	7.250
G	Mindestschwenkradius	mm 4.969	4.952	4.833
H	Min. Schütthöhe	mm 3.275	2.975	2.430
	Schaufelrotation	Grad 162	162	163
	Max. Ausbrechkraft Löffelstiel	kN 257,1	235	207,9
	Max. Reißkraft Schaufel	kN 282	282	282

3,0-M-LÖFFELSTIEL, 6,9-M-AUSLEGER, FG, 600-MM-BODENPLATTE, OHNE LÖFFEL

Reichweite	1,5 m		3 m		4,5 m		6 m		7,5 m		9 m		10 m		Hubkapazität bei max. Reichweite			
																		
Lastpunkthöhe	kg	kg	kg	kg	kg	kg	kg	kg	kg	kg	kg	kg	kg	kg	kg	kg	mm	
9 m																11.731*	11.731*	6.796
7,5 m									11.355*	11.355*						11.395*	10.588	8.030
6 m									11.820*	11.662						11.372*	8.863	8.840
4,5 m					19.956*	19.956*	15.118*	15.118*	12.827*	11.181	11.647*	8.412				11.512*	7.909	9.339
3 m							17.373*	14.576	14.023*	10.645	12.206*	8.148				11.763*	7.403	9.577
1,5 m							19.125*	13.794	15.073*	10.183	12.724	7.899				11.620	7.233	9.573
0 m					24.614*	20.276	19.968*	13.369	15.695*	9.881	12.547	7.739				11.935	7.383	9.327
-1,5 m			18.660*	18.660*	26.183*	20.333	19.840*	13.247	15.663*	9.771						12.891	7.931	8.819
-3 m			31.661*	31.661*	24.101*	20.628	18.640*	13.379	14.607*	9.889						13.354*	9.133	7.997
-4,5 m			26.270*	26.270*	20.379*	20.379*	15.749*	13.814								13.514*	11.824	6.746
-6 m																		

3,0-M-LÖFFELSTIEL, 6,9-M-AUSLEGER, VG, 600-MM-BODENPLATTE, OHNE LÖFFEL

Reichweite	1,5 m		3 m		4,5 m		6 m		7,5 m		9 m		10 m		Hubkapazität bei max. Reichweite			
																		
Lastpunkthöhe	kg	kg	kg	kg	kg	kg	kg	kg	kg	kg	kg	kg	kg	kg	kg	kg	mm	
9 m																11.731*	11.731*	6.796
7,5 m									11.355*	11.355*						11.395*	11.395*	8.030
6 m									11.820*	11.820*						11.372*	9.578	8.840
4,5 m					19.956*	19.956*	15.118*	15.118*	12.827*	12.086	11.647*	9.107				11.512*	8.568	9.339
3 m							17.373*	15.843	14.023*	11.542	12.206*	8.840				11.763*	8.039	9.577
1,5 m							19.125*	15.048	15.073*	11.075	12.740*	8.589				11.973	7.867	9.573
0 m					24.614*	22.333	19.968*	14.616	15.695*	10.769	12.930	8.427				12.301	8.038	9.327
-1,5 m			18.660*	18.660*	26.183*	22.392	19.840*	14.492	15.663*	10.658						12.940*	8.638	8.819
-3 m			31.661*	31.661*	24.101*	22.694	18.640*	14.626	14.607*	10.777						13.354*	9.944	7.997
-4,5 m			26.270*	26.270*	20.379*	20.379*	15.749*	15.068								13.514*	12.869	6.746
-6 m																		

















Hubkapazität in Längsrichtung



Hubkapazität im gesamten Schwenkbereich

- Hinweise:**
1. Die Hubkapazitäten basieren auf ISO 10567, d. h.: 75 % der Kipplast oder 87 % der Hydraulikhubkapazität – es gilt der jeweils kleinere Wert. Mit * markierte Hubkapazitäten basieren auf der Hydraulikhubkapazität.
 2. Die angegebenen Hubkapazitäten setzen festen, ebenen Grund voraus.
 3. Unterschiedliche Länder haben ggf. andere gesetzliche Bestimmungen. Fragen Sie bitte Ihren Händler.

3,3-M-LÖFFELSTIEL, 6,9-M-AUSLEGER, FG, 600-MM-BODENPLATTE, OHNE LÖFFEL

Reichweite	1,5 m		3 m		4,5 m		6 m		7,5 m		9 m		10 m		Hubkapazität bei max. Reichweite					
																				
Lastpunkthöhe	kg	kg	kg	kg	kg	kg	kg	kg	kg	kg	kg	kg	kg	kg	kg	kg	kg	mm		
9 m																		11.118*	11.118*	7.242
7,5 m									10.785*	10.785*								10.863*	9.827	8.410
6 m									11.332*	11.332*	10.858*	8.638						10.705*	8.322	9.186
4,5 m					18.831*	18.831*	14.504*	14.504*	12.385*	11.226	11.253*	8.426						10.870*	7.467	9.668
3 m					23.643*	22.011	16.822*	14.668	13.635*	10.663	11.882*	8.135						11.197	7.007	9.897
1,5 m					21.525*	20.625	18.714*	13.818	14.765*	10.167	12.491*	7.860						11.023	6.846	9.894
0 m					24.901*	20.171	19.747*	13.321	15.498*	9.826	12.477	7.667						11.293	6.971	9.656
-1,5 m			17.866*	17.866*	26.446*	20.149	19.825*	13.142	15.618*	9.676	12.422	7.616						12.120	7.446	9.166
-3 m			28.728*	28.728*	24.628*	20.396	18.869*	13.224	14.831*	9.740								12.760*	8.473	8.379
-4,5 m			28.099*	28.099*	21.281*	20.934	16.420*	13.589										12.984*	10.672	7.196
-6 m					14.908*	14.908*												12.354*	12.354*	5.329

3,3-M-LÖFFELSTIEL, 6,9-M-AUSLEGER, VG, 600-MM-BODENPLATTE, OHNE LÖFFEL

Reichweite	1,5 m		3 m		4,5 m		6 m		7,5 m		9 m		10 m		Hubkapazität bei max. Reichweite							
																						
Lastpunkthöhe	kg	kg	kg	kg	kg	kg	kg	kg	kg	kg	kg	kg	kg	kg	kg	kg	kg	kg	kg	mm		
9 m																				11.118*	11.118*	7.242
7,5 m									10.785*	10.785*										10.863*	10.477	8.410
6 m									11.332*	11.332*	10.858*	9.226								10.705*	8.892	9.186
4,5 m					18.831*	18.831*	14.504*	14.504*	12.385*	11.994	11.253*	9.011								10.870*	7.995	9.668
3 m					23.643*	23.643*	16.822*	15.753	13.635*	11.424	11.882*	8.717								11.245*	7.516	9.897
1,5 m					21.525*	21.525*	18.714*	14.889	14.765*	10.922	12.491*	8.439								11.362	7.354	9.894
0 m					24.901*	21.948	19.747*	14.384	15.498*	10.576	12.854*	8.244								11.643	7.495	9.656
-1,5 m			17.866*	17.866*	26.446*	21.926	19.825*	14.201	15.618*	10.424	12.668*	8.193								12.356*	8.009	9.166
-3 m			28.728*	28.728*	24.628*	22.179	18.869*	14.284	14.831*	10.490										12.760*	9.112	8.379
-4,5 m			28.099*	28.099*	21.281*	21.281*	16.420*	14.656												12.984*	11.474	7.196
-6 m					14.908*	14.908*														12.354*	12.354*	5.329



















Hubkapazität in Längsrichtung















Hubkapazität im gesamten Schwenkbereich

- Hinweise:**
1. Die Hubkapazitäten basieren auf ISO 10567, d. h.: 75 % der Kipplast oder 87 % der Hydraulikhubkapazität – es gilt der jeweils kleinere Wert. Mit * markierte Hubkapazitäten basieren auf der Hydraulikhubkapazität.
 2. Die angegebenen Hubkapazitäten setzen festen, ebenen Grund voraus.
 3. Unterschiedliche Länder haben ggf. andere gesetzliche Bestimmungen. Fragen Sie bitte Ihren Händler.

3,9-M-LÖFFELSTIEL, 6,9-M-AUSLEGER, FG, 600-MM-BODENPLATTE, OHNE LÖFFEL

Reichweite	1,5 m		3 m		4,5 m		6 m		7,5 m		9 m		10 m		Hubkapazität bei max. Reichweite				
																			
Lastpunkthöhe	kg	kg	kg	kg	kg	kg	kg	kg	kg	kg	kg	kg	kg	kg	kg	kg	kg	mm	
9 m																	9.084*	9.084*	7.963
7,5 m												8.926*	8.832				8.644*	8.644*	9.037
6 m									10.349*	10.349*	9.934*	8.734					8.528*	7.526	9.762
4,5 m							13.229*	13.229*	11.471*	11.337	10.477*	8.462	10.123*	7.066			8.652*	6.797	10.216
3 m					21.512*	21.512*	15.655*	14.885	12.816*	10.724	11.216*	8.125	10.544*	6.862			9.002*	6.389	10.433
1,5 m					25.166*	20.890	17.800*	13.905	14.091*	10.159	11.952*	7.799	10.773	6.652			9.616*	6.232	10.430
0 m					26.711*	20.071	19.188*	13.263	15.028*	9.740	12.365	7.547	10.605	6.498			10.300	6.315	10.205
-1,5 m	12.472*	12.472*	17.301*	17.301*	26.681*	19.846	19.660*	12.960	15.423*	9.508	12.223	7.418					10.944	6.681	9.743
-3 m	19.454*	19.454*	25.524*	25.524*	25.426*	19.971	19.156*	12.939	15.059*	9.481	11.929*	7.478					11.912*	7.470	9.008
-4,5 m	27.509*	27.509*	31.326*	31.326*	22.779*	20.394	17.407*	13.185	13.409*	9.712							12.308*	9.073	7.921
-6 m			23.825*	23.825*	17.865*	17.865*	13.270*	13.270*									12.324*	12.324*	6.299

3,9-M-LÖFFELSTIEL, 6,9-M-AUSLEGER, VG, 600-MM-BODENPLATTE, OHNE LÖFFEL

Reichweite	1,5 m		3 m		4,5 m		6 m		7,5 m		9 m		10 m		Hubkapazität bei max. Reichweite				
																			
Lastpunkthöhe	kg	kg	kg	kg	kg	kg	kg	kg	kg	kg	kg	kg	kg	kg	kg	kg	kg	mm	
9 m																	9.084*	9.084*	7.963
7,5 m												8.926*	8.926*				8.644*	8.644*	9.037
6 m									10.349*	10.349*	9.934*	9.434					8.528*	8.151	9.762
4,5 m							13.229*	13.229*	11.471*	11.471*	10.477*	9.160	10.123*	7.669			8.652*	7.383	10.216
3 m					21.512*	21.512*	15.655*	15.655*	12.816*	11.627	11.216*	8.820	10.544*	7.463			9.002*	6.957	10.433
1,5 m					25.166*	22.970	17.800*	15.165	14.091*	11.055	11.952*	8.490	10.993*	7.252			9.616*	6.799	10.430
0 m					26.711*	22.130	19.188*	14.513	15.028*	10.630	12.493*	8.236	10.939	7.096			10.597*	6.897	10.205
-1,5 m	12.472*	12.472*	17.301*	17.301*	26.681*	21.899	19.660*	14.205	15.423*	10.395	12.607	8.106					11.290	7.299	9.743
-3 m	19.454*	19.454*	25.524*	25.524*	25.426*	22.027	19.156*	14.183	15.059*	10.368	11.929*	8.166					11.912*	8.158	9.008
-4,5 m	27.509*	27.509*	31.326*	31.326*	22.779*	22.461	17.407*	14.434	13.409*	10.602							12.308*	9.896	7.921
-6 m			23.825*	23.825*	17.865*	17.865*	13.270*	13.270*									12.324*	12.324*	6.299



Hubkapazität in Längsrichtung













Hubkapazität im gesamten Schwenkbereich

- Hinweise:**
1. Die Hubkapazitäten basieren auf ISO 10567, d. h.: 75 % der Kipplast oder 87 % der Hydraulikhubkapazität – es gilt der jeweils kleinere Wert. Mit * markierte Hubkapazitäten basieren auf der Hydraulikhubkapazität.
 2. Die angegebenen Hubkapazitäten setzen festen, ebenen Grund voraus.
 3. Unterschiedliche Länder haben ggf. andere gesetzliche Bestimmungen. Fragen Sie bitte Ihren Händler.

2,55-M-HD-LÖFFELSTIEL, 6,5-M-ME-AUSLEGER, FG, 600-MM-BODENPLATTE, OHNE LÖFFEL

Reichweite	1,5 m		3 m		4,5 m		6 m		7,5 m		9 m		10 m		Hubkapazität bei max. Reichweite				
																	mm		
Lastpunkthöhe	kg	kg	kg	kg	kg	kg	kg	kg	kg	kg	kg	kg	kg	kg	kg	kg	mm		
9 m																	13.759*	13.759*	5.938
7,5 m																	12.955*	12.020	7.321
6 m							13.854*	13.854*	12.765*	11.472							12.661*	9.811	8.203
4,5 m					20.517*	20.517*	15.713*	15.522	13.512*	11.085							12.524*	8.663	8.740
3 m							17.829*	14.564	14.548*	10.611							12.801*	8.093	8.994
1,5 m							19.457*	13.845	15.456*	10.205							12.786	7.939	8.989
0 m					27.225*	20.495	20.139*	13.478	15.889*	9.963							13.254	8.185	8.727
-1,5 m					25.917*	20.607	19.730*	13.423	15.472*	9.942							13.690*	8.953	8.180
-3 m			30.051*	30.051*	23.229*	21.000	17.898*	13.670									13.724*	10.658	7.285
-4,5 m							18.010*										12.907*	12.907*	5.881
-6 m																			

2,55-M-HD-LÖFFELSTIEL, 6,5-M-ME-AUSLEGER, VG, 600-MM-BODENPLATTE, OHNE LÖFFEL

Reichweite	1,5 m		3 m		4,5 m		6 m		7,5 m		9 m		10 m		Hubkapazität bei max. Reichweite				
																	mm		
Lastpunkthöhe	kg	kg	kg	kg	kg	kg	kg	kg	kg	kg	kg	kg	kg	kg	kg	kg	mm		
9 m																	13.759*	13.759*	5.938
7,5 m																	12.955*	12.955*	7.321
6 m							13.854*	13.854*	12.765*	12.382							12.661*	10.605	8.203
4,5 m					20.517*	20.517*	15.713*	15.713*	13.512*	11.989							12.524*	9.387	8.740
3 m							17.829*	15.833	14.548*	11.510							12.801*	8.786	8.994
1,5 m							19.457*	15.102	15.456*	11.099							13.149*	8.630	8.989
0 m					27.225*	22.560	20.139*	14.728	15.889*	10.854							13.437*	8.905	8.727
-1,5 m					25.917*	22.675	19.730*	14.672	15.472*	10.833							13.690*	9.741	8.180
-3 m			30.051*	30.051*	23.229*	23.078	17.898*	14.923									13.724*	11.591	7.285
-4,5 m					18.010*	18.010*											12.907*	12.907*	5.881
-6 m																			



















Hubkapazität in Längsrichtung



















Hubkapazität im gesamten Schwenkbereich

- Hinweise:**
1. Die Hubkapazitäten basieren auf ISO 10567, d. h.: 75 % der Kipplast oder 87 % der Hydraulikhubkapazität – es gilt der jeweils kleinere Wert. Mit * markierte Hubkapazitäten basieren auf der Hydraulikhubkapazität.
 2. Die angegebenen Hubkapazitäten setzen festen, ebenen Grund voraus.
 3. Unterschiedliche Länder haben ggf. andere gesetzliche Bestimmungen. Fragen Sie bitte Ihren Händler.

3,0-M-HD-LÖFFELSTIEL, 6,5-M-ME-AUSLEGER, FG, 600-MM-BODENPLATTE, OHNE LÖFFEL

Reichweite	1,5 m		3 m		4,5 m		6 m		7,5 m		9 m		10 m		Hubkapazität bei max. Reichweite				
																			
Lastpunkthöhe	kg	kg	kg	kg	kg	kg	kg	kg	kg	kg	kg	kg	kg	kg	kg	kg	kg	mm	
9 m																	9.984*	9.984*	6.578
7,5 m										11.791*	11.744						8.972*	8.972*	7.847
6 m										11.941*	11.576						8.536*	8.536*	8.675
4,5 m						18.861*	18.861*	14.786*	14.786*	12.813*	11.140	11.910*	8.283				8.431*	7.987	9.183
3 m						23.560*	22.164	17.009*	14.672	13.953*	10.620	12.331*	8.061				8.589*	7.484	9.425
1,5 m						26.508*	20.774	18.856*	13.851	15.000*	10.158	12.682	7.837				9.019*	7.335	9.421
0 m						27.193*	20.302	19.839*	13.377	15.631*	9.852	12.540	7.708				9.807*	7.527	9.171
-1,5 m				20.658*	20.658*	26.379*	20.297	19.780*	13.231	15.540*	9.754						11.171*	8.149	8.653
-3 m				32.650*	32.650*	24.181*	20.609	18.451*	13.385	14.081*	9.945						13.041*	9.493	7.813
-4,5 m				26.168*	26.168*	19.874*	19.874*	14.771*	13.950								12.669*	12.555	6.526
-6 m																			

3,0-M-HD-LÖFFELSTIEL, 6,5-M-ME-AUSLEGER, VG, 600-MM-BODENPLATTE, OHNE LÖFFEL

Reichweite	1,5 m		3 m		4,5 m		6 m		7,5 m		9 m		10 m		Hubkapazität bei max. Reichweite						
																					
Lastpunkthöhe	kg	kg	kg	kg	kg	kg	kg	kg	kg	kg	kg	kg	kg	kg	kg	kg	kg	kg	mm		
9 m																			9.984*	9.984*	6.578
7,5 m										11.791*	11.791*								8.972*	8.972*	7.847
6 m										11.941*	11.941*								8.536*	8.536*	8.675
4,5 m						18.861*	18.861*	14.786*	14.786*	12.813*	12.047	11.910*	8.979						8.431*	8.431*	9.183
3 m						23.560*	23.560*	17.009*	15.945	13.953*	11.521	12.331*	8.755						8.589*	8.135	9.425
1,5 m						26.508*	22.850	18.856*	15.110	15.000*	11.053	12.785*	8.528						9.019*	7.985	9.421
0 m						27.193*	22.366	19.839*	14.628	15.631*	10.743	12.910*	8.398						9.807*	8.200	9.171
-1,5 m				20.658*	20.658*	26.379*	22.361	19.780*	14.480	15.540*	10.644								11.171*	8.877	8.653
-3 m				32.650*	32.650*	24.181*	22.681	18.451*	14.636	14.081*	10.837								13.041*	10.336	7.813
-4,5 m				26.168*	26.168*	19.874*	19.874*	14.771*	14.771*										12.669*	12.669*	6.526
-6 m																					



Hubkapazität in Längsrichtung



Hubkapazität im gesamten Schwenkbereich

- Hinweise:**
1. Die Hubkapazitäten basieren auf ISO 10567, d. h.: 75 % der Kipplast oder 87 % der Hydraulikhubkapazität – es gilt der jeweils kleinere Wert. Mit * markierte Hubkapazitäten basieren auf der Hydraulikhubkapazität.
 2. Die angegebenen Hubkapazitäten setzen festen, ebenen Grund voraus.
 3. Unterschiedliche Länder haben ggf. andere gesetzliche Bestimmungen. Fragen Sie bitte Ihren Händler.







KETTENBAGGER 520X

X-PECT MORE

JCB Deutschland GmbH, JCB-Allee 3, 50226 Frechen, Germany. www.jcb.de

©2026 JCB Sales. Alle Rechte vorbehalten. Dieses Dokument darf ohne vorherige Genehmigung durch JCB Sales weder vollständig noch teilweise vervielfältigt, in einem Erfassungssystem gespeichert, oder in jedweder Form sowie Methode elektronisch, mechanisch, fototechnisch oder sonst wie übermittelt werden. Sämtliche Angaben in diesem Dokument hinsichtlich Betriebsgewicht, Größe, Arbeitsgeschwindigkeit sowie sonstiger Leistungsdaten dienen nur zur Veranschaulichung und können je nach genauer Maschinenausrüstung abweichen. Sie sollten daher nicht als Nachweis zur Eignung der Maschine für einen bestimmten Einsatzzweck dienen. Lassen Sie sich unbedingt von Ihrem JCB Händler beraten. JCB behält sich das Recht vor, ohne vorherige Benachrichtigung technische Änderungen vorzunehmen. Die im Werbematerial enthaltenen Abbildungen und Angaben gelten nur als Richtlinie und können in gewissen Märkten vom Lieferumfang abweichen. Das JCB Logo ist eine eingetragene Marke von J. C. Bamford Excavators Ltd.

33424 de-DE Ausgabe 1



**ERFAHREN
SIE MEHR**

